

Features

- Race proven technology
- High temperature capability +175°C (350°F)
- Amplified or millivolt output
- Stainless steel or Titanium construction
- Fully EMC protected
- Flexible mechanical/electrical interface options

Success in Motorsport depends on hundreds of components working together under extreme conditions and GE Sensing continues to develop Druck pressure transducers that give the ultimate performance. Druck motorsport sensors have become a world-leading product line used throughout Formula 1, World Rally Championship and the Indy Racing League amongst others.

The PDCR/ PMP 4300 Series is the latest in the range of products that for many years has been "fine tuned" in design to suit all chassis and engine pressure measurement requirements. Dedicated support teams provide the focused effort required to successfully respond to the demands of this dynamic and competitive market.

PDCR/PMP 4300 Series

Druck Motorsport / Automotive Pressure Transducers

PDCR/PMP 4300 Series is a Druck product. Druck has joined other GE high-technology sensing businesses under a new name—GE Industrial, Sensing.



GE Sensing

Race Proven Technology

Since 1990 Druck products have been successfully applied to Motorsport and the PDCR/PMP 4300 Series is the latest high performance pressure sensor for this harsh environment application.

Reliability remains at the forefront of GE Sensing design and build philosophy. The combination of high technology sensing elements together with advanced signal conditioning and packaging techniques provides reliable and accurate pressure measurements.



High Performance

GE has one of the most advanced and comprehensive silicon processing facilities and is one of a few companies turning raw silicon into finished pressure sensing products.

Each pressure module is fully temperature cycled to enhance long-term measurement stability. All metalwork is Electron Beam Welded to form a rugged housing. Upon completion of the electrical connections the units are again thermally cycled to eliminate any possible defects in application.

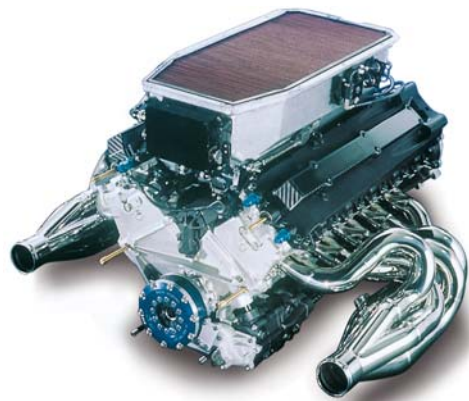

This rugged construction enables the 4300 Series to operate under extreme temperature and vibration conditions.

Flexible Design

The pressure sensing module and the electronics form a completely flexible core. Various configurations of electrical terminations and pressure connectors are available in both Stainless Steel and Titanium.

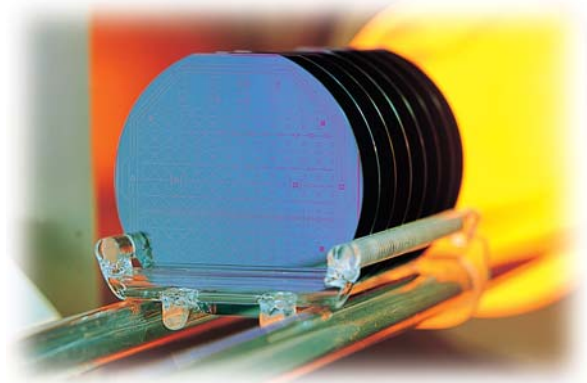

GE has considerable experience in solving specific application problems by developing standard designs to suit customer specific applications.

Technical Support

GE's quality systems meet the requirements of ISO 9001 and we are totally committed to pressure measurement excellence and the dedicated support required in such a demanding market. In the unlikely event of a sensor defect, GE Sensing would undertake an immediate and complete investigation of the failure mode and report back to customer with the fault diagnosis and the resulting corrective action.



4300 Series Specifications

Pressure Measurement

Pressure Ranges

25, 45, 145, 217, 435, 1160, 1810, 3625 psi absolute
1.6, 3, 10, 15, 30, 80, 125 and 250 bar absolute.

*Note: Any engineering pressure unit can be specified
Custom pressure ranges available - refer to GE*

Overpressure

2 x rated pressure or 4525 psi (312 bar) maximum for stainless steel
2 x rated pressure for Titanium (5800 psi (400 bar) max)

Pressure Containment

5440 psi (375 bar) max for stainless steel
7000 psi (500 bar) max for Titanium units

Media Compatibility

Fluids compatible with stainless steel 316L or Titanium IMI 160. Fluids classification in accordance with pressure equipment directive 97/23/EC

Excitation Voltage

PDCR 4300: 10 VDC nominally (other regulated d.c. excitation levels can be specified)
PMP 4300: 12 V \pm 4 VDC unregulated (at 70°F (20°C))
10V to 16 VDC unregulated (-25° to 350°F (-30° to 175°C))

Supply Current

PDCR 4300: <2 mA
PMP 4300: <5 mA

Resolution

Infinite

Zero Offset

PDCR 4300: 0 mVDC \pm 3 mVDC
PMP 4300: 0.2 VDC \pm 50 mVDC

Span setting

PDCR 4300: 50 mVDC \pm 3 mV (output ratiometric to supply)
PMP 4300: 4.7 VDC \pm 50 mVDC
Alternatives available - refer to GE.

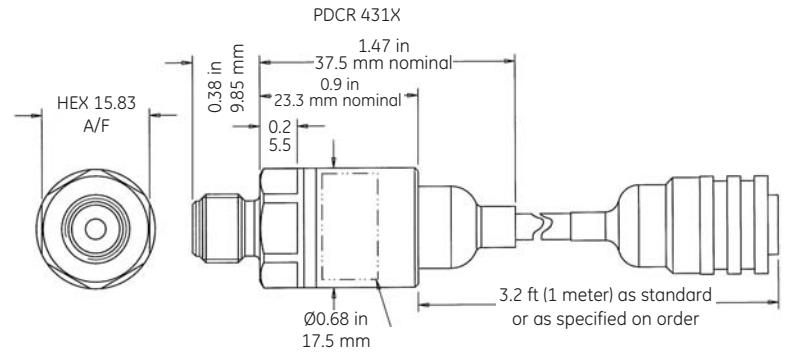

Wiring connection details PDCR/PMP 431X/439X

PCDCR 431X	PMP431X/439X
Red: PDCR: +ve supply	Red/Pin1: PMP: +ve supply
Black: PDCR: -ve supply	Black/Pin2: PMP: 0 V/common
Green: PDCR: +ve output	Green/NC: PMP: not connected
White: PDCR: -ve output	White/Pin3: PMP: +ve output
Blue: PDCR: temp. signal (if required)	Blue/Pin4: PMP: temp. signal (if required)
Screen: case connection if required	Screen/Pin5: Always connected to case

Note: temp signal not available if case connection is required on the PDCR 439X or PDCR 439X.

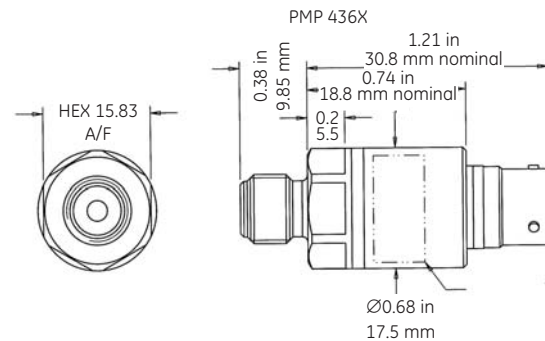

Wiring connection details PMP/PDCR 436X

PCDCR 436X	PMP436X
Pin 1: PDCR: +ve supply	PMP: +ve supply
Pin 2: PDCR: -ve supply	PMP: 0 V/common
Pin 3: PDCR: +ve output	PMP: +ve output
Pin 4: PDCR: -ve output	PMP: temp. signal (if req'd)
Pin 5: PDCR: temp. signal/case connection if required.	PMP: case connection

Note: if specifying PDCR 4300 with temperature signal for connector version, pin to case connection is not available

Performance Specification

Accuracy

- \pm 0.1% full scale (FS) Best Straight Line (BSL) for ranges up to (and including) 870 psi (60 bar)
- \pm 0.2% FS BSL for ranges above 870 psi (60 bar)

Long term stability

<0.1% FS/year

Operating temperature range

-25° to 350°F (-30° to 175°C)

Compensated temperature range

-25° to 350°F (-30° to 175°C)

Alternative temperature ranges available - refer to GE

GE Sensing

Thermal performance

PDCR 4300:
Thermal zero/span shift : $\pm 1.5\% \text{ FS}/210^\circ\text{F} \text{ (}100^\circ\text{C)}$
PMP 4300:
Thermal Zero/Span shift : $\pm 1\% \text{ FS}/210^\circ\text{F} \text{ (}100^\circ\text{C)}$

Temperature signal output (optional)

PDCR 4300: 2.8 VDC \pm 1.4 VDC at 70°F (20°C)
PMP 4300: 2.9 VDC \pm 0.5 VDC at 70°F (20°C)

Temperature signal sensitivity (optional)

PDCR 4300: 3 mV/°C \pm 2 mV/°C
PMP 4300: 7 mV/°C \pm 1 mV/°C

Insulation resistance

>100 MΩ at 50 VDC

Output impedance

PDCR 4300: 2 kΩ nominal
PMP 4300: <math><100 \Omega</math>

Physical Specification

Pressure connection

Select from the following standard fittings (all male fittings): M8 x 1, M10 x 1, M10 x 1 snubber, 5/16" - 4UNJF, 3/8" - 24UNJF, 1/8" NPT, 1/8" BSP,
Alternatives available - refer to GE.

Electrical connection

- 1 metre of 5 core Raychem cable spec EPD 96401A
- 5 pin Deutsch Hermetic AS-Micro
- 1 metre of 5 core Raychem cable spec EPD 96401A and 5 pin Deutsch Hermetic AS-Micro

Installation torque

10 Nm will produce negligible zero offset

Weight

PDCR 4300
AS micro stainless steel: <math><1 \text{ oz (}28 \text{ g)}</math>
AS micro Titanium: <math><0.5 \text{ oz (}16 \text{ g)}</math>
Cable and stainless steel: <math><1.8 \text{ oz (}53 \text{ g)}</math>
Cable and Titanium: <math><1.5 \text{ oz (}43 \text{ g)}</math>
Cable versions quoted with 40 in (1 metre) of cable.
PMP 4300:

AS micro stainless steel: <math><1 \text{ oz (}30 \text{ g)}</math>
AS micro Titanium: <math><0.6 \text{ oz (}19 \text{ g)}</math>
Cable and stainless steel: <math><2 \text{ oz (}57 \text{ g)}</math>
Cable and Titanium: <math><1.5 \text{ oz (}45 \text{ g)}</math>
Cable versions quoted with 40 in (1 metre) of cable.

Vibration

50 to 2500 Hz @ 40g, 8 hours per axis, logarithmic sweep at a rate of 0.32 octaves/minute with no effect on calibration

Shock

1000 g 1 mS half sine pulse in all 3 axes with no effect on calibration

EMC

CE mark statement 'CE marked for electromagnetic compatibility'

Options

- (1) Mating electrical connector (supplied loose).
- (2) Temperature signal output.
- (3) Additional cable (state length).

Calibration Standards

Transducers manufactured by GE are calibrated against precision pressure calibration equipment which is traceable to International Standards.

Ordering Information

Please state the following:

(1) Specify model number e.g. PMP 4392

Code	Output	Code	Electrical Connect
PMP 43XX	Amplified	1	DR25 sleeved cable (1m as standard)
PDCR 43XX	Millivolt	6	Autosport 5 pin connector
		9	DR25 sleeved cable and autosport 5 pin connector
		Code	Electrical Connections
		1	Stainless steel
		2	Titanium
PMP 43	9	—	2
Typical model number			

- (2) Pressure range.
- (3) Pressure units.
- (4) Compensated temperature range.
- (5) Pressure connection.
- (6) Options if required.
- (7) 439X version specify cable length.

EX-CALIBRA
Autoryzowany dystrybutor
GE Measurement & Control Solutions
41-400 Mysłowice, ul. Portowa 25
tel.: 32 2239280, fax: 32 2239281
e-mail: ex-calibra@ex-calibra.pl
Internet: www.ex-calibra.pl



All specifications are subject to change for product improvement without notice. GE® is a registered trademark of General Electric Co. Other company or product names mentioned in this document may be trademarks or registered trademarks of their respective companies, which are not affiliated with GE.

www.gesensing.com